

# STRUCTURAL ENGINEERING IN TERMS OF DENSED HOUSING SYSTEM WITH ALLOWANCE FOR INSOLATION

Alexander L. Kheyfets

South Ural State University, Chelyabinsk, Russia

heifets@yandex.ru

## ABSTRACT

The problem of a new building system within the existing residential area is considered in the article. Models and algorithms that help to calculate allowable space for a new building of a free form that won't reduce insolation of the buildings below allowable standards, are developed. Algorithm which helps to provide necessary insolation of a new building is considered. This model is realized by means of AutoCAD with AutoLisp. Algorithm for a model as well as the example for the calculation is given in the article.

## Keywords

insolation, structural architectural design, computer simulation, geometric simulation, 3D-technologies, AutoCAD, AutoLisp.

## 1. INTRODUCTION

The erection of new buildings in the areas of constructed residential areas increases the role of the calculation of duration of insolation as a geometric factor that constrains the housing density. Modern methods and algorithms [1–3] allow us to calculate insolation by means of successive approximation only which makes this calculation quite problematic.

The objective of this article is to develop an algorithm of insolation calculation in terms of densed housing system.

Let us consider two problems. *Problem 1*: determination of allowable space for housing system, in which the erection of a building of any form will not reduce insolation of old buildings that are below allowable standards [1]. *Problem 2*: provision of allowable insolation of a new building under the influence of old buildings.

Methods of solution are based on the analysis and use of 3d-computer geometric simulation by means of AutoCAD [4]. The calculation of length and area within insolation boundaries is performed with the program [5]. This algorithm is implemented by AutoLisp. This model is considered on the basis of typical housing development.

## 2. ALLOWABLE AREA FOR HOUSING DEVELOPMENT

The calculation of insolation boundaries of residential area (fig. 1) demonstrates inner zones of high insolation. This fact determines the possibility of placing a new building within this zone.

We construct the frame  $k$  for housing development and the overall volume  $V$  by vertical pulling of  $k$  (fig. 2, *a*). We place check points of the windows (fig. 2, *b*), in which we need to keep allowable insolation.

The calculation is performed on the day of equinox. The flux of sun rays directed in each check point presents a radial plane  $\gamma$  (see fig. 3, *a*). Angle  $\varphi$  is equal to geographic latitude of the area. In each point, let us take point  $A$  as an example, we build section of the buildings by radial plane and define sector  $L$  of insolation acting till the erection of a new building. Single sector  $\beta$  is formed for continuous insolation (fig. 3, *b*). Interrupted insolation with several sectors  $L$  is possible.

Within  $L$  we shall mark allowable insolation  $D, D_1, D_2$ , (fig. 3, *c, d*). Ray volumes  $V_d (V_1, V_2 \dots)$  are formed by the vertical pulling of  $D$  sectors. After subtraction of  $V_d$  from  $V$  we have volume  $V'$ , provid-

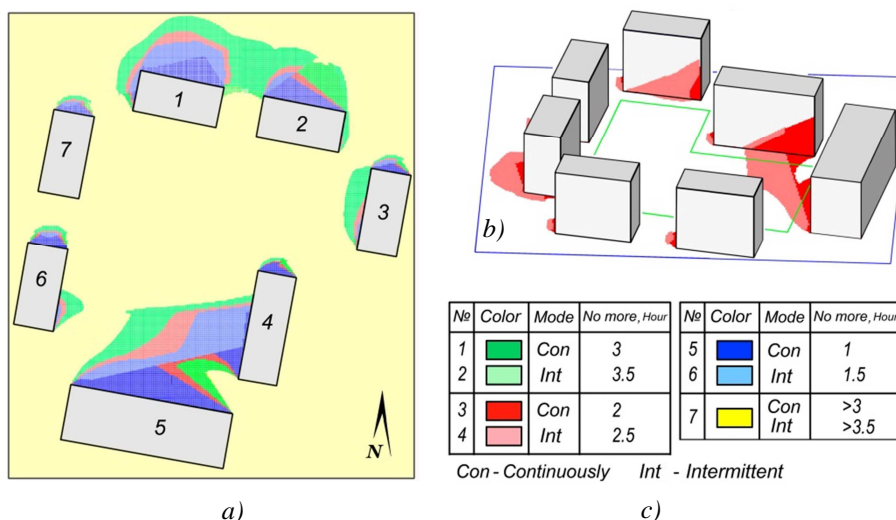

**Fig. 1. Model of a residential area and its initial solar exposure:**

*a* – field of solar exposure on the scheme; *b* – solar exposure of the walls (zones №. 3, 4); *c* – shading of the zones of solar exposure

ing insolation in point A (fig. 3, e, f).

Within sector  $L$  we can assign either single sector  $D$ , lasting for 2 hours ( $30^\circ$ ) and creating a continuous residual insolation (see fig. 3, c), or several sectors  $D$  with a total duration of 2.5 hours ( $37.5^\circ$ ), creating disruptive insolation (see fig. 3, d). Apart from the quantity we can vary the placement of  $D$  inside  $L$ .

Within the frame of housing system  $k$  we define the set of basic points  $P_{bi}$  on a uniform grid (some points  $P_{bi}$  are given on

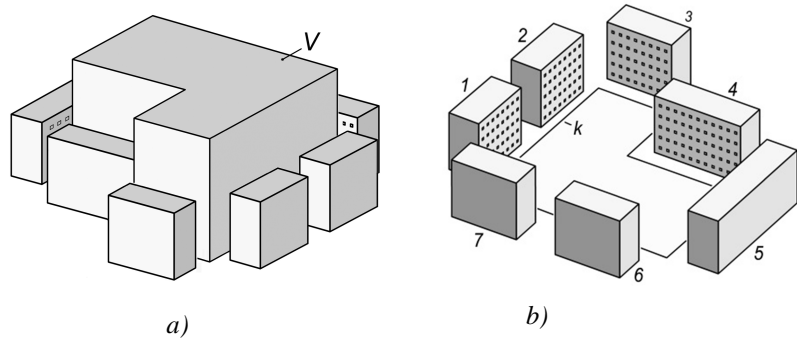

**Fig. 2. Initial volume of a housing system (a), check points of the windows (b)**

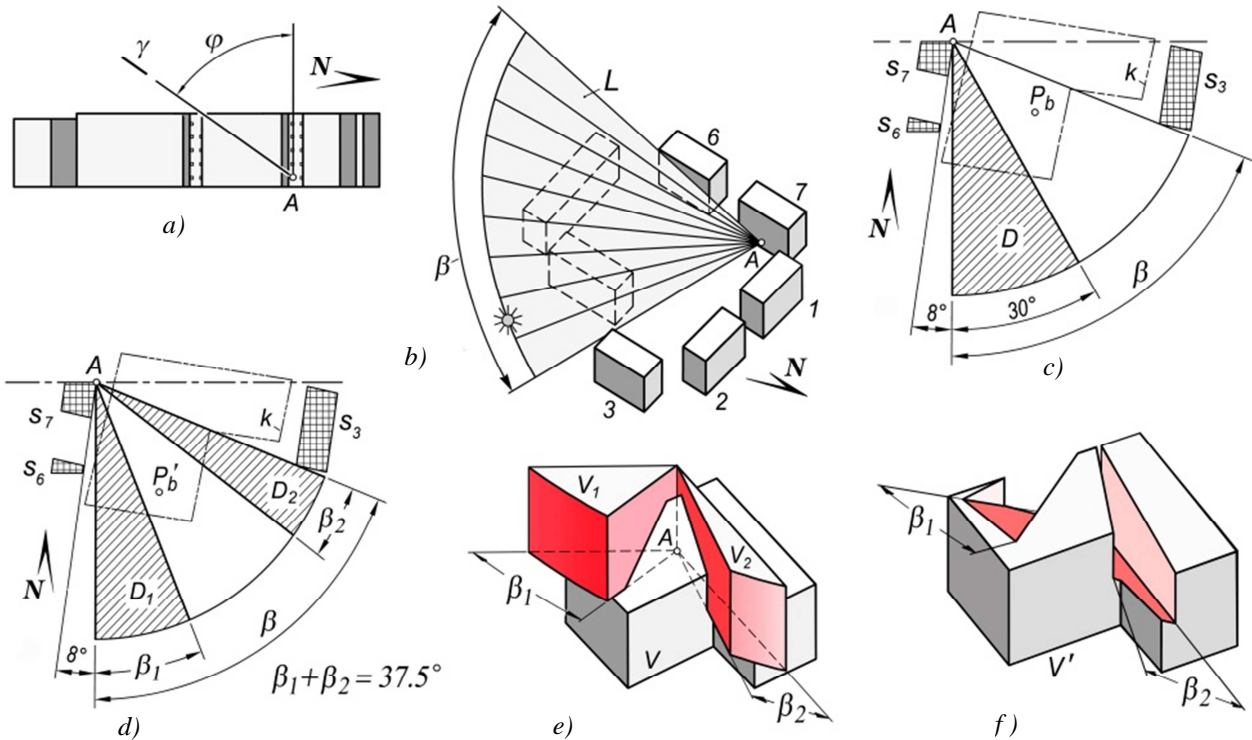

**Fig. 3. Algorithm of Problem 1:**

a – planes of equinox; b, c, d – sectors of permitted solar exposure at point A; e, f – subtraction of volumes of permitted solar exposure

fig. 4, a). For each point  $P_{bi}$  we form the set of sectors  $D$  of all check points, providing the area  $R_i$  of a maximum free space around  $P_{bi}$ .

Among the range of basic points we shall find point  $P_{bmax}$ , its area  $R_{max}$ , is a maximum one (fig. 4, b). Point  $P_{bmax}$  is considered to be optimal. Ray volumes  $V_d$  for all check points, defined for point  $P_{bmax}$ , are subtracted from initial volume  $V$  of housing development.

Final volume is a multifaceted body (fig. 5, a). After cutting off an unconstructive part the design of a new building is done (fig. 5, b), which guarantees allowable insolation at check points of old buildings.

In the given example the number of check points (windows) is 250, while the number of basic points on the frame is 120.

## 2. INSOLATION OF A NEW BUILDING

Let us put the markers of check points on the walls – windows (in our example there are 400 markers, fig. 5, b). At each point we replace the wall by the screen. We shall calculate insolation at the point. If it is of allowable level, we shall keep the position of the point without any changes. If insolation is below allowable level, we move the point, for example  $C$  (fig. 6, a), located on the wall  $w$ , into the depth of a building together with its screen  $e$ . Trajectory of movement  $m$  is perpendicular to the plane of the wall. The point is moved until insolation reaches its allowable level. We shall mark sector of allowable insolation  $D_c$ , and form volume  $V_c$ , let us subtract it from the volume of initial model (fig. 6, c). For point  $C^*$  volume  $V_c$  (see fig. 6, c volume  $V_c$  is relatively raised up) is obtained by pulling frame  $D_c$ , down at value  $d$ , it equals the height of the floor, and by pulling it up above the level of

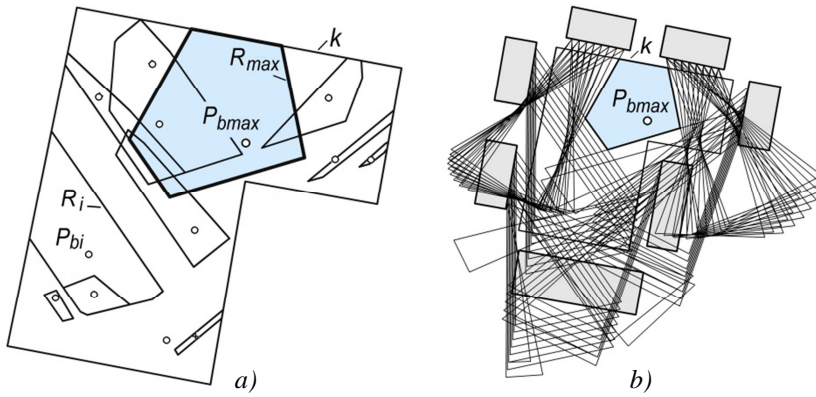

**Fig. 4. Algorithm of optimization of Problem 1:**  
*a* – high-bay areas; *b* – sectors of light for optimal basic point

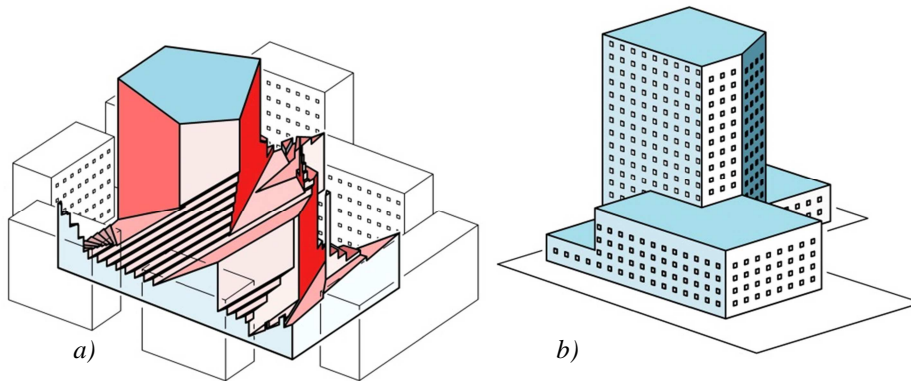

**Fig. 5. Problem 1:** *a* – overall volume; *b* – model inserted in volume

the model. After subtracting all the volumes of  $V_c$  we shall have a model. (fig. 6, *d*).

According to Problem 2 some changes of the model and organizational actions are necessary. Some faces of the office and high part of a building are turned at  $20...30^\circ$  (fig. 7, *a*). Although it will lead to the reduction of

building area it will also provide its complete insolation. In the office area we provide parking space and warehouse where standard insolation is not required.

Fields of insolation demonstrate (fig. 7, *b*), that insolation of walls of old and new buildings is in allowable level.

### 3 ALGORITHM OF PROBLEM 1

Calculation of allowable volume of the housing development system is the problem of optimization. Its analytical solution is not possible due to nonlinear effect of the range of parameters.

Algorithm which is connected with the selection of parameters of sectors  $D$  at every check point of the window  $P_k$  and calculation of optimal result in terms of placing a new building with a maximum allowable area of plan  $S$  for a high area is developed. Parameter of optimization is basic point  $P_b$  which is moved within frame  $k$  (fig. 4, *b*).

$G$  is basic data to calculate geometry of old buildings,  $k$  is frame,  $V$  is initial volume,

$MPk(m)$  is a massive of check points - windows),  $MPb(n)$  is a massive of basic points.

At every point of a massive  $MPk(m)$  we calculate sector  $L$  of initial insolation (see. fig. 3, *b*) and form a massive  $ML(m)$  of the parameters for the sectors.

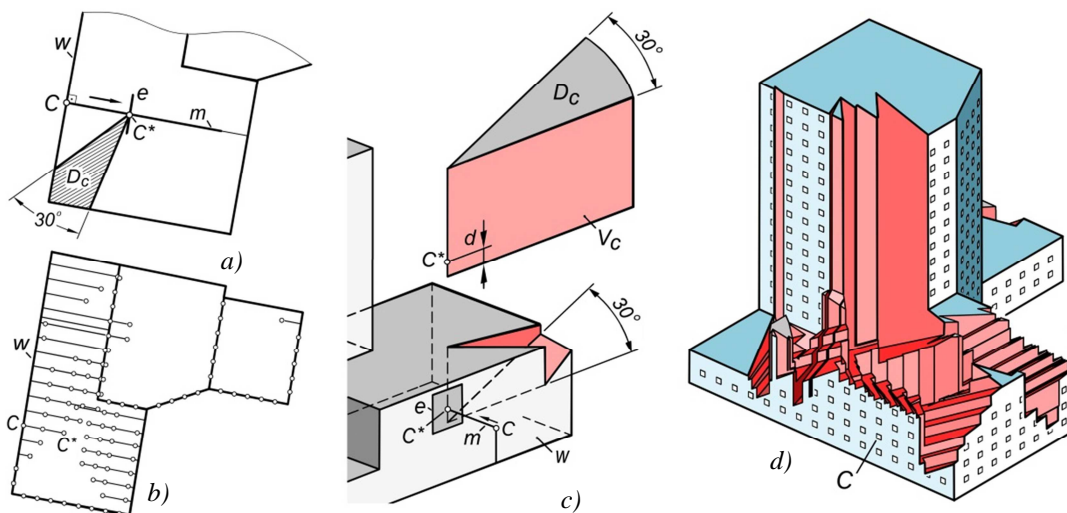

**Fig. 6. Algorithm of Problem 2:** *a* – formation of sector of permitted solar exposure; *b* – movement of check points; *c* – subtraction of sector at point  $C$ ; *d* – subtraction of all sectors

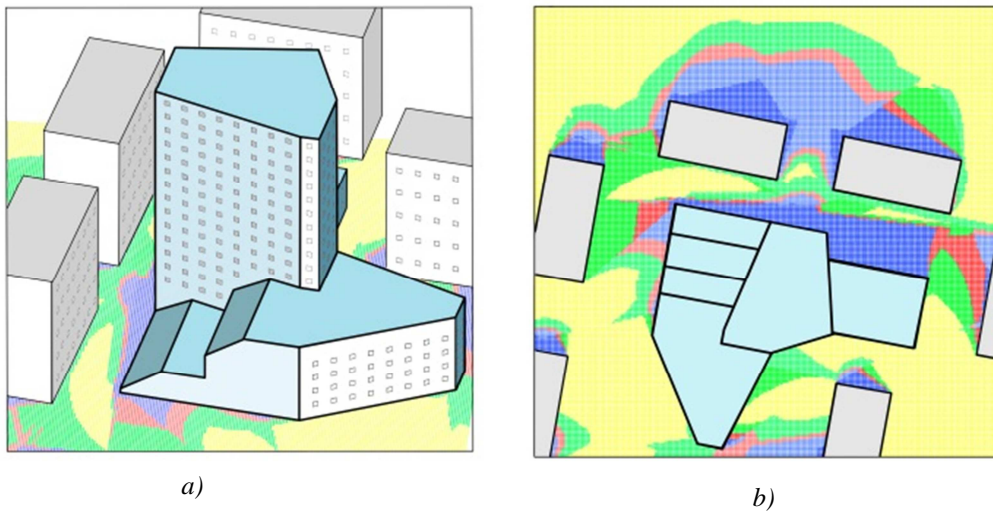

**Fig. 7. Final adjustment of the model of a new building:**  
*a* – model; *b* – solar exposure after adjustment

For every basic point  $P_{bi}$  of a massive  $MPb(n)$  we shall form a massive  $MD(m, i)$  of sectors  $D$  of all points of a massive  $MPk(m)$ . We shall calculate sectors  $D$  to provide area  $R_i$  of a maximum allowable area  $S_i$  round the points  $P_{bi}$  (see fig. 4, *a*).

Algorithm for sectors  $D$  formation provides 20 variants of their placement within sectors  $L$  depending on the size of the sectors  $L$ , type of initial insolation ( $Con$ ,  $Int$ , see fig. 1) and the position of basic point  $P$ .

Let us insert parameters  $MD(m, i)$  to massive  $MD(m, n)$ . We shall insert geometry of areas  $R_i$  (see fig. 4, *a*) of all basic points to massive  $MR(n)$ .

In a massive  $MR(n)$  we shall find area  $R_{max}$  of a maximum area  $S_{max}$  and corresponding basic point  $P_{bmax}$ , which are considered to be optimal. From massive  $MD(m, n)$  we shall extract  $MD(R_{max})$  of sectors  $D$  to the area  $R_{max}$ , we shall build ray volumes from these sectors, and form a massive  $MV(R_{max})$ , which is to be subtracted from basic volume  $V$ . Volume  $V^*$  obtained is considered to be the solution of the problem 1.

**Fig. 8. Block scheme of problem 1**

volume  $V$ . Volume  $V^*$  obtained is considered to be the solution of the problem 1.

## SUMMARY

1. Model under consideration and algorithms of 3d-computer geometric simulation for its implementation

allow defining allowable volume of housing system under guaranteed insolation of new and old buildings.

2. Fields of insolation are an effective and strategic geometric method of its analysis.

3. The model given shows the possibilities of modern methods of 3d computer geometric simulation in the solution and analysis of the problems, for which the use of traditional analytic or project methods is impossible or irrational.

## REFERENCES

- [1] Hygienic requirements for insolation and solar control premises of inhabited and public buildings and grounds [Sanitarnye pravila i normy SanPiN 2.2.1/2.1.1.1076-01: Gigienicheskie trebovaniya k insoljácii i solncezashhite pome-shhenij zhilyh i obshhestvennyh zdaniy i territorij: utv. Glavnym gosudarstvennym sanitarnym vrachom RF 19 oktjabrja 2001 g.]: <http://best-stroy.ru/gost/r38/311>.
- [2] Sitis: Soljaris 5.15.11311 (17.08.2011): <http://sitis.ru/soft/solaris>.
- [3] Kheyfets A.L. Insolation Duration Calculating by Means of 3D-Modelling Program Autocad. 7th International Conference 3IA'2003. 12-13 of May. 2004. Limoges. France. Computer Graphics and Artificial Intelligence. Organised by MSI Laboratory of the University de Limoges. pp. 177–180.
- [4] Kheyfets A.L., Loginovskij A.N., Butorina I.V., Vasil'eva V.N. Engineering 3d computer graphics [Inzhenernaja 3D-komp'juternaja grafika. AutoCAD]. Moscow, Izdatel'stvo Jurajt, 2011. 464 p.
- [5] Kheyfets A.L. The program of the automatic calculation of the insolation [Programma avtomaticheskogo rascheta insoljacji]. Svidetel'stvo o gosudarstvennoj registracii programmy JeVM №2010613828. Zajavka № 2010612286. Data postuplenija 23 aprilja 2010 g.